



InvenSense Inc.
1197 Borregas Avenue, Sunnyvale, CA 94089 U.S.A.
Tel: +1 (408) 988-7339 Fax: +1 (408) 988-8104
Website: www.invensense.com

PS-IDG-1123B-00-05
Release Date: 06/09/08

IDG-1123 Dual-Axis Gyro Product Specification

A printed copy of this document is
NOT UNDER REVISION CONTROL
unless it is dated and stamped in red ink as,
“REVISION CONTROLLED COPY.”

This information furnished by InvenSense is believed to be accurate and reliable. However, no responsibility is assumed by InvenSense for its use, or for any infringements or patents or other rights of third parties that may result from its use. Specifications are subject to change without notice. Certain intellectual property owned by InvenSense and described in this document is patent protected. No license is granted by implication or otherwise under any patent or patent rights of InvenSense. This is an unpublished work protected under the United States copyright laws. This work contains proprietary and confidential information of InvenSense Inc. Use, disclosure or reproduction without the express written authorization of InvenSense Inc. is prohibited. Trademarks that are registered trademarks are the property of their respective companies.

This publication supersedes and replaces all information previously supplied. InvenSense sensors should not be used or sold for the development, storing, production and utilization of any conventional or mass-destructive weapons or any other weapons or life threatening applications, as well as to be used in any other life critical applications such as medical, transportation, aerospace, nuclear, undersea, power, disaster and crime prevention equipment. InvenSense does not warrant and shall not be liable for application-specific use.

Copyright ©2008 InvenSense Corporation.



TABLE OF CONTENTS

1. REVISION HISTORY	4
2. PURPOSE	5
3. PRODUCT OVERVIEW	5
4. FEATURES	5
5. FUNCTIONAL BLOCK DIAGRAM	6
6. FUNCTIONAL DESCRIPTION	6
6.1 OVERVIEW	6
6.2 RATE SENSORS	6
6.3 OSCILLATOR CIRCUIT	6
6.4 AMPLITUDE CONTROL	6
6.5 CORIOLIS SENSE	7
6.6 DEMODULATOR	7
6.7 LOW-PASS FILTER	7
6.8 HIGH-PASS FILTER	7
6.9 PROGRAMMABLE GAIN	7
6.10 HIGH-PASS FILTER RESET SWITCH	7
6.11 OUTPUT BUFFER	7
6.12 REFERENCE VOLTAGE	7
6.13 CHARGE PUMP	7
6.14 EEPROM TRIM	7
6.15 SCALE FACTOR	7
7. SPECIFICATION	8
7.1 SPECIFIED PARAMETERS	8
7.2 ABSOLUTE MAXIMUM RATINGS	9
7.3 REFERENCE CIRCUIT	9
7.4 BILL OF MATERIAL FOR EXTERNAL COMPONENTS	9
8. APPLICATION INFORMATION	10
8.1 PIN OUT AND SIGNAL DESCRIPTION	10
8.2 DESIGN CONSIDERATIONS	11
8.2.1 POWER SUPPLY REJECTION RATIO	11
8.2.2 POWER SUPPLY FILTERING	11
8.2.3 AMPLITUDE CONTROL	11
8.2.4 INTERNAL LOW-PASS FILTER	11
8.2.5 HIGH-PASS FILTER	12



8.2.6	HIGH-PASS FILTER RESET	12
8.2.7	EXTERNAL LOW-PASS FILTER	12
8.2.8	V ₂₀ CHARGE PUMP	13
8.2.9	ELECTROSTATIC DISCHARGE SENSITIVITY.....	13
9.	ASSEMBLY	14
9.1	ORIENTATION	14
9.2	PACKAGE DIMENSIONS	14
9.3	PACKAGE MARKING SPECIFICATION.....	15
9.4	TAPE & REEL SPECIFICATION.....	15
9.4.1	LABEL	17
9.4.2	PACKING	17
9.5	PCB PAD LAYOUT DIMENSIONS	18
9.6	TRACE ROUTING.....	18
9.7	SOLDERING EXPOSED DIE PAD	18
9.8	COMPONENT PLACEMENT	18
9.9	PCB MOUNTING AND CROSS-AXIS SENSITIVITY	18
9.10	AGC NODES	19
9.11	MEMS HANDLING INSTRUCTIONS.....	19
9.12	GYROSCOPE SURFACE MOUNT GUIDELINES	19
9.13	REFLOW SPECIFICATION	20
9.14	STORAGE SPECIFICATION	20
10.	RELIABILITY	21
10.1	QUALIFICATION TEST POLICY	21
10.2	QUALIFICATION TEST PLAN	21
11.	ENVIRONMENTAL COMPLIANCE.....	23



1. Revision History

Revision Date	Revision
02/01/08	01
03/03/08	02
05/23/08	03
05/28/08	04
06/09/08	05

Preliminary



2. Purpose

The purpose of this document is to provide a detailed product description and design-related information regarding the IDG-1123 dual-axis gyroscope.

3. Product Overview

The IDG-1123 gyroscope utilizes state-of-the-art MEMS fabrication with wafer-scale integration technology. This technology combines completed MEMS wafers and completed CMOS electronic wafers together using a patented and proprietary wafer-scale bonding process that simultaneously provides electrical connections and hermetically sealed enclosures. This unique and novel fabrication technique is the key enabling technology that allows for the design and manufacture of high performance, multi-axis, integrated MEMS gyroscopes in a very small and economical package. Integration at the wafer-level minimizes parasitic capacitances, allowing for improved signal-to-noise over a discrete solution. It also enables the incorporation of a rich feature set which minimizes the need for external amplification.

4. Features

By integrating the control electronics with the sensor elements at the wafer level, the IDG-1123 gyroscope supports a rich feature set including:

- a) Integrated X- and Y-axis gyro on a single chip
- b) Factory calibrated scale factor
- c) Integrated low-pass filters with two phase options
- d) User defined high-pass filters
- e) Integrated reset switches for high-pass filters
- f) High vibration rejection over wide frequency range
- g) High cross-axis isolation by design
- h) 3V single-supply operation
- i) RoHS and Green Compliant

5. Functional Block Diagram

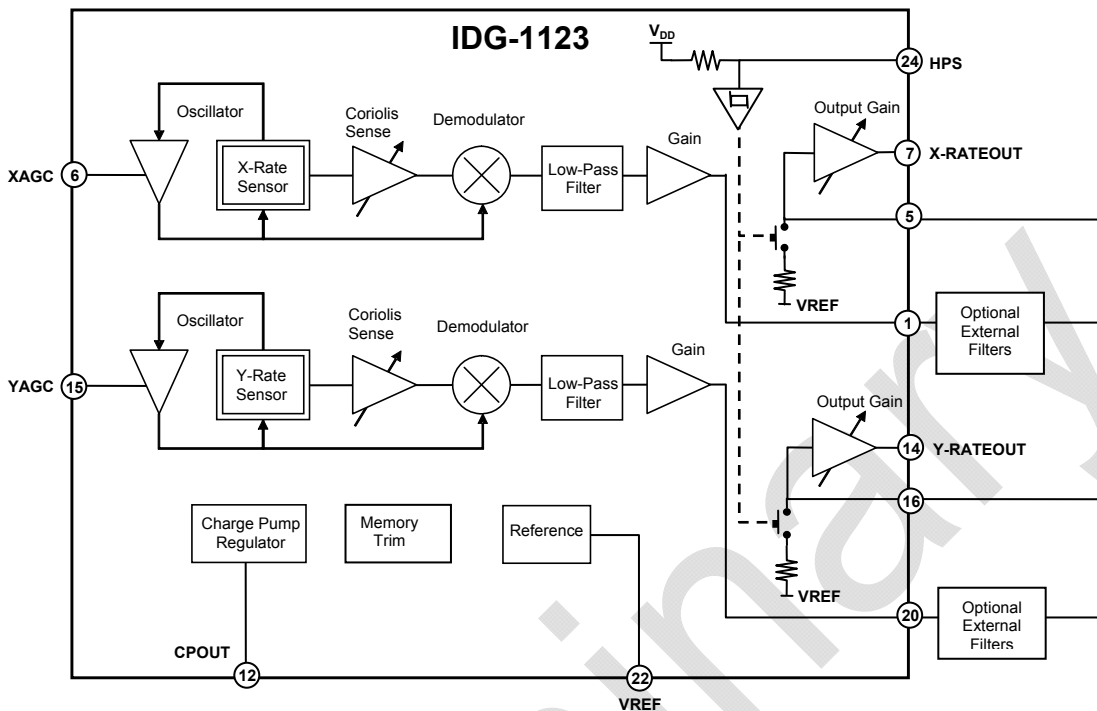

Figure 1

6. Functional Description

6.1 Overview

The IDG-1123 gyroscope consists of two independent vibratory MEMS gyroscopes. One detects rotation about the X-axis; the other detects rotation about the Y-axis.

The gyroscope's proof-masses are electrostatically oscillated at resonance. An internal automatic gain control circuit precisely controls the oscillation of the proof masses. When the sensor is rotated about the X- or Y-axis, the Coriolis effect causes a vibration that can be detected by a capacitive pickoff. The resulting signal is amplified, demodulated, and filtered to produce an analog voltage that is proportional to the angular rate.

6.2 Rate Sensors

The mechanical structures for detecting angular rate about the X and Y axes are fabricated using InvenSense's proprietary bulk silicon technology. The structures are covered and hermetically sealed at the wafer level. The cover shields the gyro from electromagnetic and radio frequency interferences (EMI/RFI). The dual-mass design inherently rejects any signal caused by linear acceleration. The X-gyro and the Y-gyro have different resonant frequencies to prevent undesired coupling.

6.3 Oscillator Circuit

The oscillator circuit generates electrostatic forces to vibrate the structure at resonance. The circuit detects the vibration by measuring the capacitance between the oscillating structure and a fixed electrode. The oscillator circuit switches in quadrature phase with the capacitance measurement in order to vibrate at resonance.

6.4 Amplitude Control

The scale factor of the gyroscope depends on the amplitude of the mechanical motion and the trim setting of the internal programmable gain stages. The oscillation circuit precisely controls the amplitude to maintain



constant sensitivity over the temperature range. The capacitors connected to Pin 6 (XAGC) and Pin 15 (YAGC) are compensation capacitors for the amplitude control loops.

6.5 Coriolis Sense

Rotating the sensor about the X- or Y-axis results in a Coriolis force on the corresponding X- or Y-rate sensor. The Coriolis force causes the mechanical structure to vibrate in-plane. The resulting vibration is detected by measuring the capacitance change between the mechanical structure and fixed electrodes. This signal is converted to a voltage waveform by means of low-noise charge integrating amplifier and amplification stages.

6.6 Demodulator

The output of the Coriolis sense is an amplitude modulated waveform. The amplitude corresponds to the rotation rate, and the carrier frequency is the mechanical drive frequency. The synchronous demodulator converts the Coriolis sense waveform to the low-frequency, angular rate signal.

6.7 Low-Pass Filter

After the demodulation stage, there is a low-pass filter. This filter attenuates noise and high frequency artifacts before final amplification.

6.8 High-Pass Filter

Use of high-pass filters are required in order to minimize DC rate offset variation over temperature. The high-pass filters are implemented with external passive components.

6.9 Programmable Gain

The signal chain includes several stages of amplification. The gain of these stages is adjusted and trimmed at the factory to provide a calibrated sensitivity. The calibrated sensitivity values are stored in on-chip memory that is programmed at the factory.

6.10 High-Pass Filter Reset Switch

Integrated switches can be used to reset the external high-pass filters. It may be desirable to reset the high-pass filters' capacitors during power-up or after certain user-defined conditions.

6.11 Output Buffer

The output of the gyro is factory programmed. A Rate-Out voltage higher than the Reference Voltage corresponds to a positive rotation.

6.12 Reference Voltage

The gyro includes a bandgap reference circuit. The output voltage is typically 1.23V and is nominally independent of temperature. The zero-rate signal is nominally equal to the reference value.

6.13 Charge pump

The on-chip charge pump generates the voltage required to oscillate the mechanical structure.

6.14 Memory Trim

The on-chip memory is used to select the gyro's sensitivity, calibrate the sensitivity, null DC offsets and select the low-pass filter option.

6.15 Scale Factor

The Rate-Out of the gyro is not ratiometric to the supply voltage. The scale factor is calibrated at the factory and is nominally independent of supply voltage.



7. Specification

7.1 Specified Parameters

All the parameters listed are specified at $V_{DD}=3.0V$ and $T=25^{\circ}C$ and are measured with the circuit in Figure 2 unless otherwise noted. All specifications apply to both the X and Y axes.

Parameters	Conditions	Symbol	Min	Typical	Max	Unit
SENSITIVITY						
Full-Scale Range	Factory Set			±43		°/s
Sensitivity				23		mV/°/s
Initial Calibration Tolerance				±6		%
Over Specified Temperature				±10		%
Nonlinearity	Best Fit Straight Line			<1		% of FS
Cross-axis Sensitivity				±1		%
ZERO-RATE OUTPUT (w/HPF)						
Static Output (Bias)				1.23		V
Initial Calibration Tolerance				±100		mV
Over Specified Temperature				±50		mV
Power Supply Rejection Ratio	@ 50 Hz			10		°/s/V
FREQUENCY RESPONSE						
High Frequency Cutoff	Internal LPF -90°		120	140	200	Hz
LPF Phase	10Hz			-4.5		°
MECHANICAL FREQUENCIES						
X-Axis Resonant Frequency			20	24	28	kHz
Y-Axis Resonant Frequency			23	27	31	kHz
Frequency Separation	X and Y Gyroscopes			3		kHz
NOISE PERFORMANCE						
Total RMS Noise	Bandwidth 1Hz to 1kHz				5	mV rms
Low Frequency Noise	Bandwidth 1Hz to 10Hz			2		mV rms
OUTPUT DRIVE CAPABILITY						
Output Voltage Swing	Load = 100kΩ to $V_{dd}/2$		0.05		$V_{dd}-0.05$	V
Capacitive Load Drive				100		pF
Output Impedance				100		Ω
REFERENCE						
Voltage Value		VREF		1.23		V
Tolerance				±50		mV
Load Drive	Load directly connected to VREF			100		μA
Capacitive Load Drive	VDD= 2.7V to 3.3V			100		pF
Over Specified Temperature				±5		mV
POWER-ON TIME						
Zero-Rate Output	Settling to ±3°/sec, HPS active 200ms			130	200	ms
HPF RESET SWITCH						
On-Resistance		HPS		650		Ω
HPS Logic High	Rising Input			1.9		V
HPS Logic Low	Falling Input			0.9		V
POWER SUPPLY						
Operating Voltage Range		VDD	2.7	3.0	3.3	V
Quiescent Supply Current				7	8	mA
Over Specified Temperature				±1		mA
TEMPERATURE RANGE						
Specified Temperature Range			-5		+75	°C
Extended Temperature Range	Performance parameters are not applicable beyond Specified Temperature Range		-20		+85	°C

7.2 Absolute Maximum Ratings

Stress above those listed as “Absolute Maximum Ratings” may cause permanent damage to the device. This is a stress rating only and functional operation of the device under these conditions is not implied. Exposure to the absolute maximum rating conditions for extended periods may affect device reliability.

Parameter	Rating
Supply Voltage	-0.3V to +3.6V
Acceleration (Any Axis, unpowered)	10,000g for 0.3ms
Operating Temperature Range	-40 to +105°C
Storage Temperature Range	-40 to +125°C

7.3 Reference Circuit

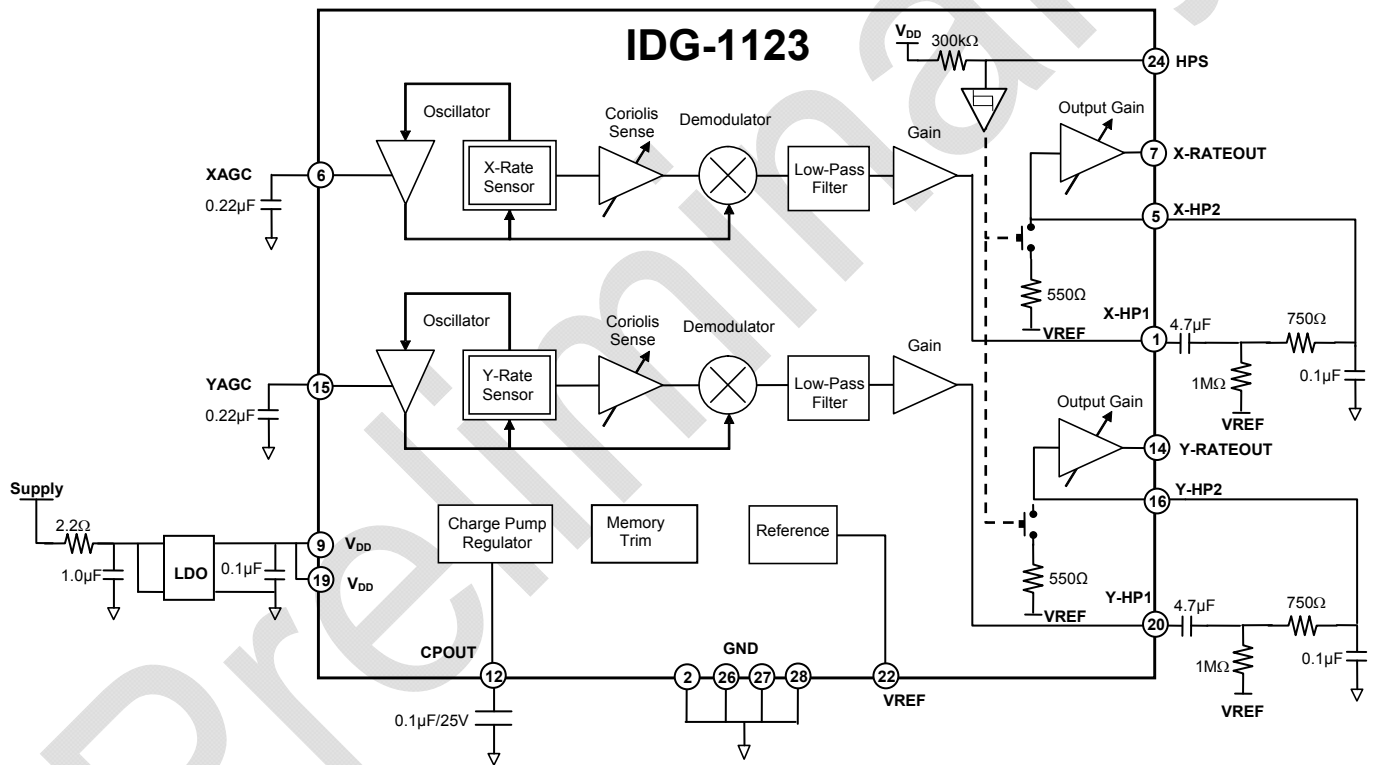

Figure 2

7.4 Bill of Material for External Components

Component	Specification
High Pass Filter Capacitors	4.7uF ±20% / 6.3V
Low Pass Filter Capacitors	0.1uF ±20% / 10V
AGC Capacitors	0.22uF ±10% / 10V
VDD Bypass Capacitor	0.1uF ±20% / 10V
Charge Pump Capacitor	0.1uF ±20% / 25V
LDO Input Filter Capacitor	1.0uF / Ratings Dependent upon Supply Voltage
LDO Input Filter Resistor	2.2 Ohm ±1%
Low Pass Filter Resistors	750 Ohm ±1%
High Pass Filter Resistors	1MOhm ±1%

8. Application Information

8.1 Pin Out and Signal Description

Number	Pin	Description
2, 26, 27, 28	GND	Ground
9, 19	VDD	Positive supply voltage: 3.0V to 3.3V.
1	XHP1	High Pass Filter input for X-axis.
6	XAGC	Amplitude control capacitor.
5	XHP2	High Pass Filter output for X-axis.
7	X-RATE OUT	Rate output for rotation about the X-axis.
12	CPOUT	Charge Pump Capacitor
14	Y-RATE OUT	Rate output for rotation about the Y-axis.
16	YHP2	High Pass Filter output for Y-axis.
15	YAGC	Amplitude control capacitor
20	YHP1	High Pass Filter input for Y-axis
22	VREF	Precision reference output.
24	HPS	X & Y High Pass Filter Switch control pin.
8, 10, 11, 13, 21, 23, 25	RESV	Reserved. Do not connect. Used for factory trimming.
3, 4, 17, 18	NC	Not internally connected. May be used for PCB trace routing.

Top View

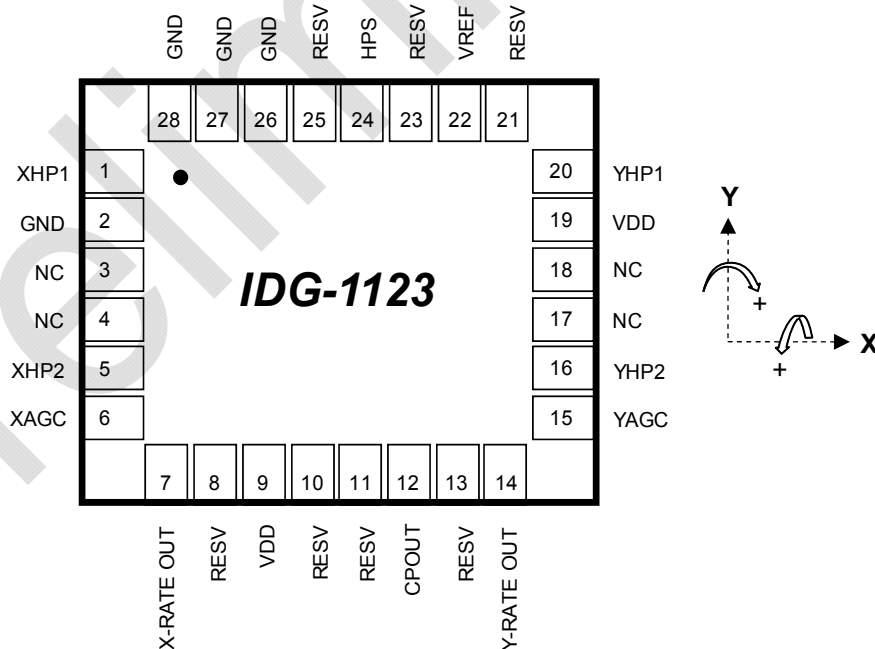

**28-pin, 4mm x 5mm x 1.2mm
QFN Package**

Figure 3

8.2 Design Considerations

8.2.1 Power Supply Rejection Ratio

The gyro is most susceptible to power supply noise (ripple) at frequencies less than 100Hz. At less than 100Hz, the PSRR is determined by the overall internal gain of the gyroscope. Above 100Hz, the PSRR is determined by the characteristics of the on-chip low-pass filter. Above 1kHz, the PSRR is relatively constant except for two narrow frequency ranges corresponding to the resonant frequencies of the X and Y gyroscopes.

8.2.2 Power Supply Filtering

The Power Supply Voltage (VDD) rise time (10% - 90%) must be less than 20ms at VDD (Pin 9) for proper device operation.

The IDG-1123 gyroscope can be isolated from system power supply noise by a combination of an RC filter that attenuates high frequency noise and a Low Drop Out power supply regulator (LDO) that attenuates low frequency noise. Figure 5 shows a typical configuration.

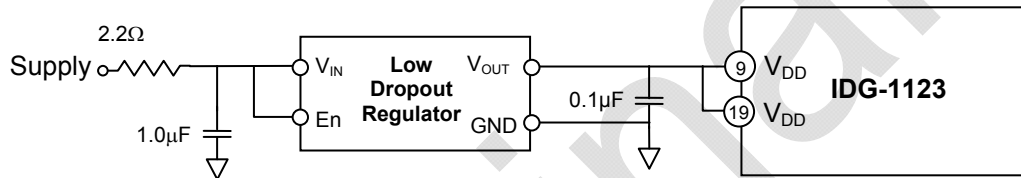

Figure 5

The low-pass RC filter should be chosen such that it provides significant attenuation of system noise at high frequencies. The LDO should be a low noise regulator ($<100\mu\text{V}/\text{rtHz}$) that exhibits good noise rejection at low frequencies. Use of IDG-1123 without LDO is not recommended.

8.2.3 Amplitude Control

The scale factor of the gyroscope depends on the amplitude of the mechanical motion. The oscillation circuit controls the amplitude to maintain constant sensitivity over the specified temperature range. The capacitors connected to Pin 6 (XAGC) and Pin 15 (YAGC) are compensation capacitors for the amplitude control loops.

8.2.4 Internal Low-Pass Filter

After the demodulation stage, there is a low-pass filter. This filter limits noise and high frequency artifacts from the demodulator before final amplification. The following graphs show the typical gain and phase responses of the two low-pass filter options. The LPF filter has been designed for a nominally flat gain up to the cutoff frequency while still achieving a low phase delay at 10Hz and 30Hz.

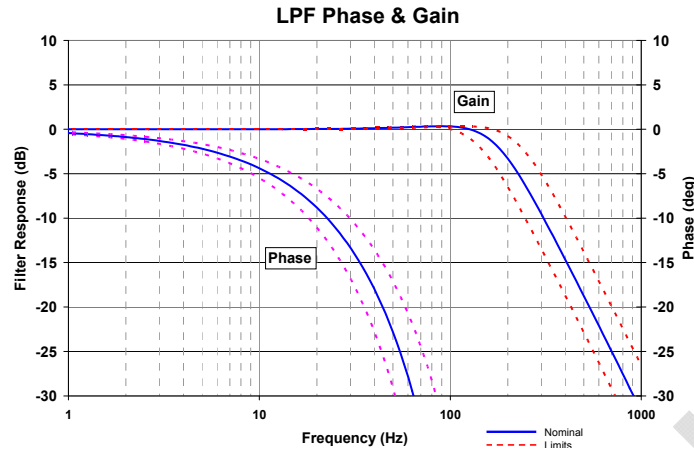

Figure 6

8.2.5 High-Pass Filter

A high-pass filter is used to minimize DC rate offset variation due to temperature. The high-pass filters are implemented by connecting an RC combination between XHP1 and XHP2 and between YHP1 and YHP2 as shown in Figure 2. The cut-off frequency for the filters is defined by $f_{cutoff} = 1/2\pi RC$. The following table shows examples of HPF configurations.

Cut-off Frequency (Hz)	Resistor (kΩ)	Capacitor (μF)
0.03	1000	4.7
0.1	330	4.7
0.3	330	1.5

8.2.6 High-Pass Filter Reset

The IDG-1123 gyroscope circuitry includes integrated switches to reset the external high-pass filters. The switches are activated by bringing the HPS Pin 24 high. This closes the switches and shorts the capacitors to V_{REF} , allowing the high-pass filter capacitors to charge up quickly. Without the high-pass filter reset switch, the high-pass filters can take several seconds to initialize. It is recommended to reset the high-pass filters at startup and during overload conditions. The HPS Pin has an internal pull-up resistor of 300kΩ. During normal operation, the HPS Pin should be pulled low. Note that the HPS input buffer is a Schmitt buffer with approximately 1.0V of hysteresis.

8.2.7 External Low-Pass Filter

To further attenuate high-frequency noise, a second external low-pass filter with a cutoff frequency of 2kHz is recommended. Suggested RC values for R_{LPX}/R_{LPY} and C_{LPX}/C_{LPY} are 750Ω and 0.1μF respectively. The placement of the LPF is shown in Figure 7.

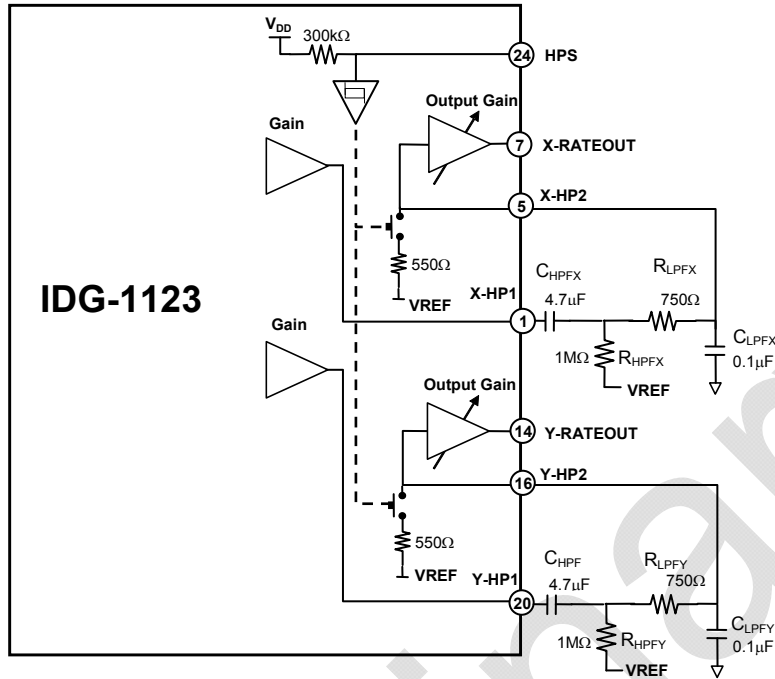

Figure 7

8.2.8 V₂₀ Charge Pump

The on-chip charge pump requires a capacitor for stable operation. This capacitor should be 0.1μF and rated for 25V.

8.2.9 Electrostatic Discharge Sensitivity

The IDG-1123 gyroscope can be permanently damaged by an electrostatic discharge. ESD precautions for handling and storage are recommended.

9. Assembly

9.1 Orientation

The diagram below shows the orientation of the axes of sensitivity and the polarity of rotation.

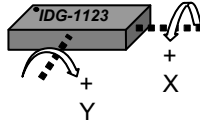
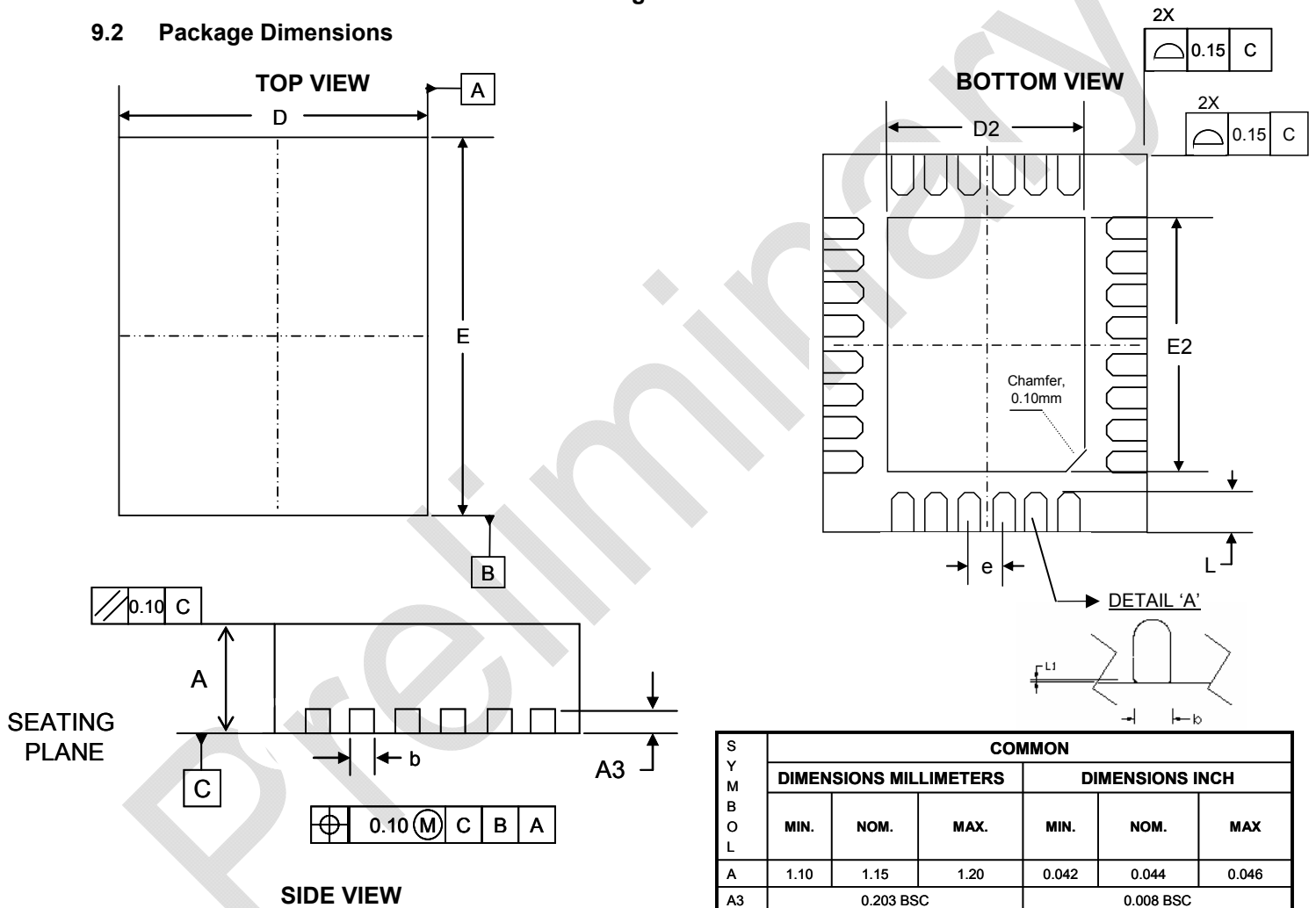

Figure 8

9.2 Package Dimensions



SYMBOL	COMMON					
	DIMENSIONS MILLIMETERS			DIMENSIONS INCH		
	MIN.	NOM.	MAX.	MIN.	NOM.	MAX.
A	1.10	1.15	1.20	0.042	0.044	0.046
A3	0.203 BSC			0.008 BSC		
b	0.18	0.25	0.30	0.007	0.009	0.011
D	3.85	4.00	4.15	0.150	0.156	0.161
D2	2.65	2.80	2.95	0.103	0.109	0.115
E	4.85	5.00	5.15	0.189	0.195	0.200
E2	3.50	3.65	3.80	0.137	0.142	0.148
e	0.50 BSC			0.019 BSC		
L	0.30	0.35	0.40	0.011	0.013	0.015
L1	0.00	0.08	0.15	0.000	0.003	0.006

Figure 9

9.3 Package Marking Specification

- Line 1 = Company Name
- Line 2 = Part Number
- Line 3 = Lot Traceability Code
- Line 4 = Fabrication, Assembly, Date Code, Revision

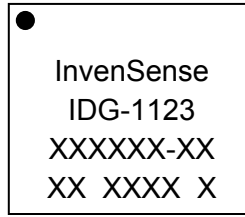

TOP VIEW

9.4 Tape & Reel Specification

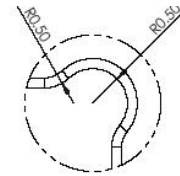
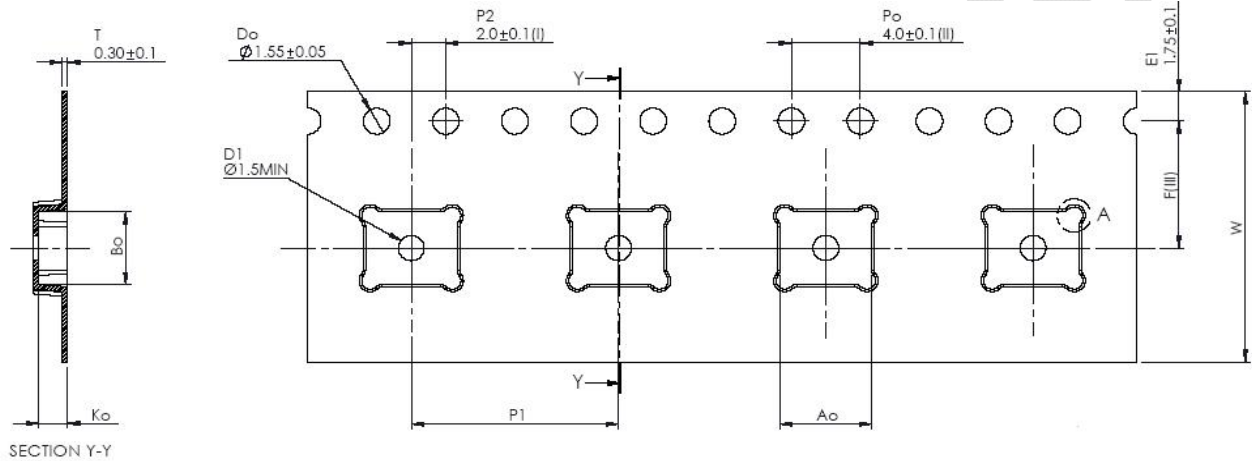

DETAIL 'A'

- (I) Measured from centerline of sprocket hole to centerline of pocket.
 - (II) Cumulative tolerance of 10 sprocket holes is ± 0.20 .
 - (III) Measured from centerline of sprocket holes to centerline of pocket.
 - (IV) Other material available.
- ALL DIMENSIONS IN MILLIMETERS UNLESS OTHERWISE STATED.

Figure 10

PKG SIZE	CARRIER TAPE (mm)							
	Tape Width (W)	Pocket Pitch (P1)	Ao	Bo	Ko	F	Leader Length (Min.)	Trailer Length (Min.)
4x5	16.00 ± 0.3	12.00 ± 0.1	5.30 ± 0.1	4.30 ± 0.1	1.65 ± 0.1	7.50 ± 0.1	300	300

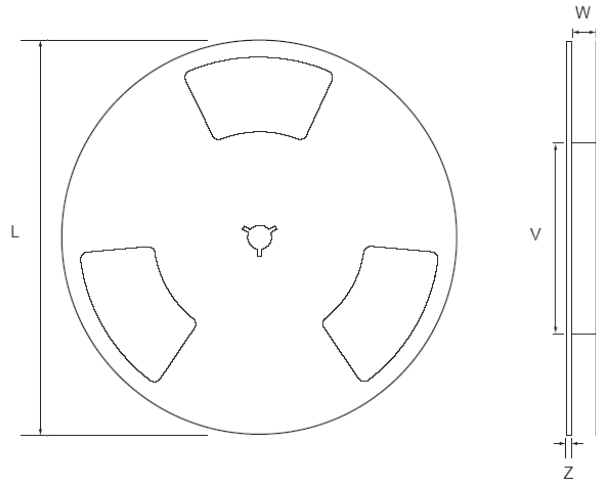

Figure 11

PKG SIZE	REEL (mm)			
	L	V	W	Z
4x5	330	100	16.4	3.0

Package Orientation

User Direction of Feed

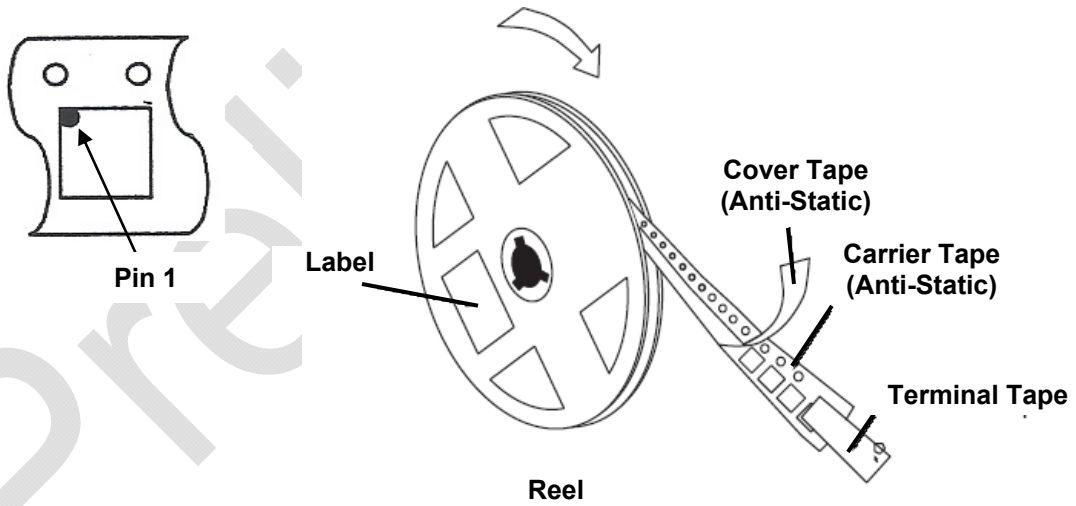

Figure 12

Quantity Per Reel	3000
Reels per Pizza Box	1
Pizza Boxes Per Carton (max)	10
Pcs/Carton (max)	30,000



**IDG-1123 Dual-Axis Gyroscope
Product Specification**

PS-IDG-1123B-00-05
Release Date: 06/09/08

9.4.1 Label

InvenSense
 DEVICE (1P) : IDG-XXXXX
 LOT 1 (1T) : XXXXXX-X D/C (D) : XXXX
 LOT 2 (1T) : XXXXXX-X D/C (D) : XXXX
 Reel Date: XX/XX/XX

REEL QTY (Q) : XXXX
 QTY (Q) : XXXX
 QTY (Q) : XXXX
 QC STAMP



Location of Label

9.4.2 Packing



Moisture Barrier Bag
With Labels

Anti-static Label
 Moisture-Sensitive
Caution Label
 Tape & Reel Label



Moisture-Sensitive Caution Label



Reel in Pizza Box



Pizza Box with Tape & Reel Label

9.5 PCB Pad Layout Dimensions

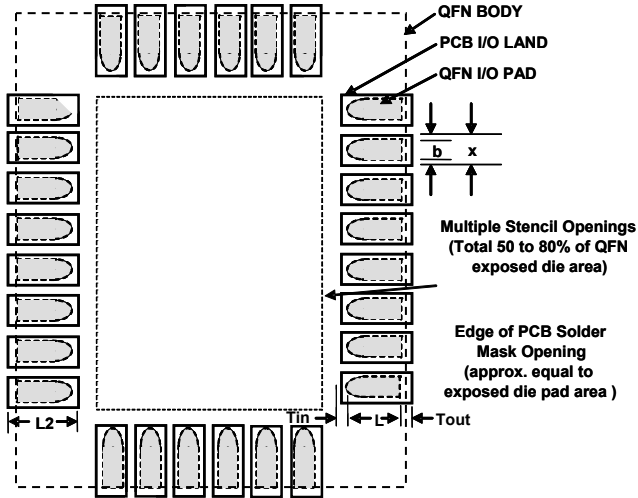

NOMINAL PACKAGE I/O PAD DIMENSIONS (mm)	
Pad Pitch	0.50
Pad Width (b)	0.25
Pad Length (L)	0.40
I/O LAND DESIGN DIMENSIONS GUIDELINES (mm)	
Land Width (x)	0.30
Outward Extension (T_{out})	0.05
Inward Extension (T_{in})	0.05
Land Length (L_2)	0.50
Sq. Stencil Openings (c)	0.5 x 0.5
Maximum Dimension (Z_{max})	4.9 x 5.9

9.6 Trace Routing

Our testing indicates that 3-Volt peak-to-peak signals run under the gyro package or directly on top of the package of frequencies from DC to 1MHz do not affect the operation of the gyro. Routing traces or vias under the gyro package is prohibited. The exposed die pad in the package is internally shorted to Pin 2 (GND).

9.7 Soldering Exposed Die Pad

The exposed die pad is internally connected to VSS. The exposed die pad should not be soldered to the PCB since it contributes to certain performance changes due to package stress.

9.8 Component Placement

Our testing indicates that there are no specific design considerations other than generally accepted industry design practices for component placement near the IDG-1123 gyroscope to prevent noise coupling.

9.9 PCB Mounting and Cross-Axis Sensitivity

Orientation error of the gyroscope mounted to the printed circuit board can cause cross-axis sensitivity in which one gyro responds to rotation about the other axis, for example, the Y-axis gyroscope responding to rotation about the X-axis. The orientation mounting error is illustrated in Figure 13.

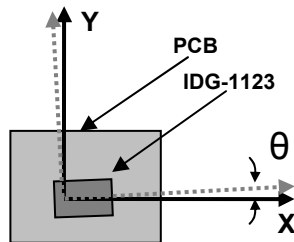

Packaged Gyro Axis (-----) Relative to PCB Axes (—) with Orientation Error θ .

Figure 13

The table below shows the cross-axis sensitivity as a percentage of the specified gyroscope's sensitivity for a given orientation error.



**IDG-1123 Dual-Axis Gyroscope
Product Specification**

PS-IDG-1123B-00-05
Release Date: 06/09/08

Orientation Error	Cross-Axis Sensitivity
Theta (θ)	$\sin\theta$
0°	0%
0.5°	0.87%
1°	1.75%

The specification for cross-axis sensitivity in Section 7.1 includes the effect of the die orientation error with respect to the package.

9.10 AGC Nodes

The gyro pins marked XAGC and YAGC are high impedance nodes that are sensitive to current leakage, which can impact gyroscope performance. Care should be taken to ensure that these nodes are not contaminated by residue such as flux and are clean.

9.11 MEMS Handling Instructions

MEMS (Micro Electro-Mechanical Systems) are a time-proven, robust technology used in tens of millions of consumer, automotive and industrial products. MEMS devices consist of microscopic moving mechanical structures. They differ from conventional IC products even though they can be found in similar packages. Therefore, MEMS devices require different handling precautions than conventional ICs prior to mounting onto printed circuit boards (PCBs).

InvenSense's dual-axis gyroscopes have a shock tolerance of 10,000g. InvenSense packages its gyroscopes as it deems proper for protection against normal handling and shipping. It recommends the following handling precautions to prevent potential damage.

1. Individual or trays of gyroscopes should not be dropped on hard surfaces. Components in trays if dropped could be subjected to g-forces in excess of 10,000g.
2. Printed circuit boards with mounted gyroscopes should not be separated by manually snapping apart. This could create g-forces in excess of 10,000g.

9.12 Gyroscope Surface Mount Guidelines

Any material used in the surface mount assembly process of the MEMS gyroscope should be free of restricted RoHS elements or compounds. Pb-free solders should be used for assembly.

In order to assure gyroscope performance, several industry standard guidelines need to be considered for surface mounting. These guidelines are for both printed circuit board (PCB) design and surface mount assembly and are available from packaging and assembly houses.

When using MEMS gyroscope components in plastic packages, package stress due to PCB mounting and assembly could affect the output offset and its value over a wide range of temperatures. This is caused by the mismatch between the Coefficient Temperature Expansion (CTE) of the package material and the PCB. Care must be taken to avoid package stress due to mounting.

9.13 Reflow Specification

The approved solder reflow curve shown in Figure 14 conforms to IPC/JEDEC J-STD-020C (reflow) for peak 255 +0/-5°C for lead free solder.

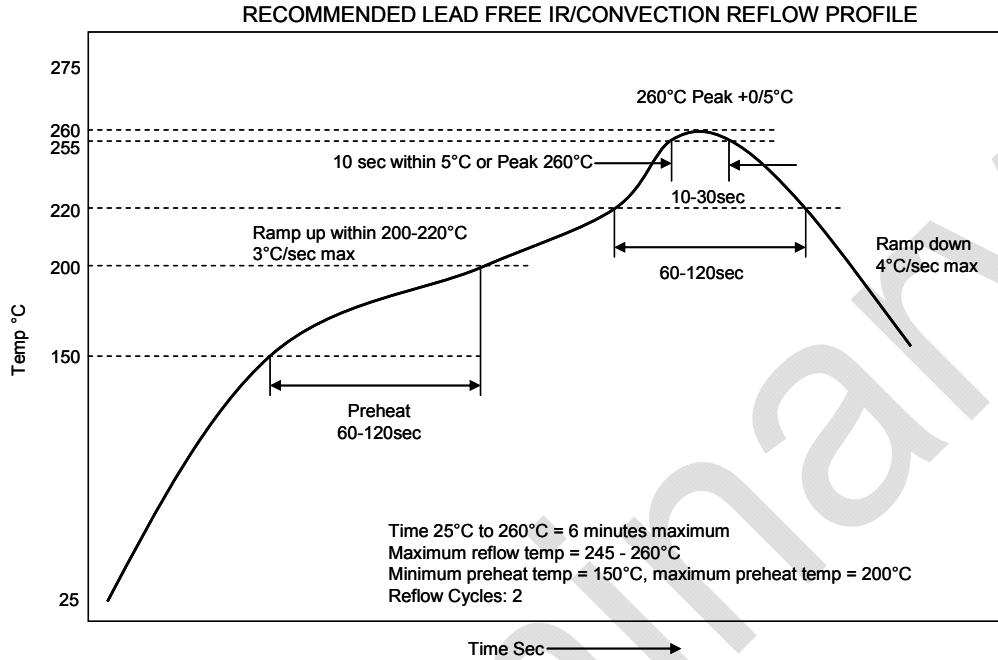

Figure 14

All temperatures refer to the topside of the package, measured on the package body surface. It is important to control the peak temperatures below recommended maximums.

9.14 Storage Specification

The storage specification of the IDG-1123 gyroscope conforms to IPC/JEDEC J-STD-020C MSL 3.

Calculated shelf-life in moisture-sealed bag	12 months -- Storage conditions: <40°C and <90% RH
After opening moisture-sealed bag	168 hours -- Storage conditions: ambient ≤30°C at 60% RH



10. Reliability

10.1 Qualification Test Policy

InvenSense’s products complete a Qualification Test Plan before being released to production. The Qualification Test Plan follows the JEDEC 47D standard (“Stress-Test-Driven Qualification of Integrated Circuits”) with the individual tests described below.

10.2 Qualification Test Plan

Accelerated Life Tests

Test	Conditions	Test Point(s)			Standard
Preconditioning/ IRR (MSL 3) ⁽¹⁾	30°C/60%RH	192Hr			JEDEC 22-A113-D Level 3
	IRR@260°C max	3X			
Temperature Cycling	-40°C/+85°C	25X	100X		JEDEC 22-A104-B Condition N
High Temp Op. Life (biased)	125°C	168Hr	500Hr	1000Hr	JEDEC 22-A108-B
Steady State Temperature, Humidity Life (unbiased)	85°C/85%RH	168Hr	500Hr	1000Hr	JEDEC 22-A101-B
High Temperature Storage	+125°C	168Hr	500Hr	1000Hr	JEDEC 22-A103-C Condition A
Low Temperature Storage	-40°C	168Hr	500Hr	1000Hr	JEDEC 22-A119 Condition A

NOTES:

(1) To precede Temperature Cycle, Steady State Temperature, Humidity Life Tests

Mechanical Tests

Test	Conditions	Test Points	Standard
Vibration, Variable Frequency (Random)	3.1G RMS, 2-500Hz, each axis	30min	JEDEC 22-B103-B Condition A
Mechanical Shock	0.3ms, 5 X/direction	10,000G	JEDEC 22-B104-C



Electrical Tests

Test	Conditions	Test Point(s)	Standard
ESD	Human Model (100pF)	2kV 1X/pin	JEDEC 22-A114-C.01 Class 2
	Machine Model (200pF)	200V, 1X/pin	JEDEC 22-A115-A Class B
Latch Up	Ambient Room Temperature	1X/pin	EIA/JESD78 Class 1

Preliminary



**IDG-1123 Dual-Axis Gyroscope
Product Specification**

PS-IDG-1123B-00-05
Release Date: 06/09/08

11. Environmental Compliance

The IDG-1123 gyroscope is RoHS and Green compliant.

Device: IDG-1123
Package Type: QFN 28L 4x5
Package Total Mass (mg): 68.75

Component	Substance	CAS Number	Percent (%)	Material Weight (mg)	Amount of Substance (mg)
-----------	-----------	------------	-------------	----------------------	--------------------------

Semiconductor Device

Silicon Chip	Doped Silicon (Si)	7440-21-3	100	11.45	11.45001
--------------	--------------------	-----------	-----	-------	----------

Lead-frame (F28L 118X150 QFN 5x4 HALF ETCH MTR Full PPF ASM)

Component	Substance	CAS Number	Percent (%)	Material Weight (mg)	Amount of Substance (mg)
Base Metal	Copper (Cu)	7440-50-8	Balance	27.76	26.76122
Base Metal	Iron (Fe)	7439-89-6	2.1-2.6		0.65236
Base Metal	Phosphorus (P)	7723-14-0	0.015-0.15		0.02290
Base Metal	Zinc (Zn)	7440-66-6	0.05-0.20		0.03472
Plating	Nickel (Ni)	7440-02-0	0.97		0.26936
Plating	Palladium (Pd)	5/3/7440	0.06		0.01667
Plating	Gold (Au)	7440-57-5	0.01		0.00278

Bond Wire (GOLD WIRE 1.00MIL GLD TANAKA)

Gold Metal	Gold (Au)	7440-57-5	>99.99	0.35	0.395
------------	-----------	-----------	--------	------	-------

Die Attach Adhesive (EPOXY DA6501 NON-CONDUCTIVE DOW CORNING)

Component	Substance	CAS Number	Percent (%)	Material Weight (mg)	Amount of Substance (mg)
Filler	Dimethyl Siloxane, Dimethylvinylsiloxy-Terminated	068083-19-2	Balance	0.31	0.26713
Filler	Trimethylated Silica	068909-20-6	7-13		0.03070
Filler	Dimethyl, Methylhydrogen Siloxane, Hydrogen-Terminated	069013-23-6	1-5		0.00921

Mold Compound (COMPOUND GREEN CEL9220HF13H HITACHI)

Component	Substance	CAS Number	Percent (%)	Material Weight (mg)	Amount of Substance (mg)
Filler	Epoxy Resin-1	Trade Secret	2-5	28.88	1.01076
Filler	Epoxy Resin-2	Trade Secret	1-3		0.57758
Filler	Phenol Resin	Trade Secret	2-5		1.01076
Hardener	Silica	60676-86-0	Balance		23.18964
Coloring Material	Carbon Black	1333-86-4	Approx. 0.2		0.05776
Filler	Metal Hydroxide	Trade Secret	1-10		1.58833
-	Others	-	Max. 5		1.44394

Test results for RoHS banned substances/compounds:

Substance/Compound	Test Method	Die	Lead-frame	Bond Wire	Die Attach Adhesive	Mold Compound
Hexavalent Chromium	EPA3060A/ 7196A	Not Available	ND(<5)	ND(<2)	ND(<1)	ND (<2)
Cadmium	EN1122 Method B:2001	Not Available	ND(<5)	ND(<2)	ND(<2)	ND (<2)
Mercury	US EPA 3052	Not Available	ND(<5)	ND(<2)	ND(<2)	ND (<2)
Lead	US EPA 3050B	Not Available	ND(<10)	ND(<2)	ND(<2)	ND (<2)
PBBs	EPA3540B/ 3550B	Not Available	ND(<250)	ND(<5)	ND(<5)	ND(<5)
PBDEs	EPA3540B/ 3550B	Not Available	ND(<250)	ND(<5)	ND(<5)	ND(<5)

ND = Not Detected

Environmental Declaration Disclaimer:

InvenSense believes this environmental information to be correct but cannot guarantee accuracy or completeness. Conformity documents for the above component are on file. InvenSense subcontracts manufacturing and the information contained herein is based on data received from vendors and suppliers. This information has not been validated by InvenSense.