



Dual-Axis MEMS Gyro Evaluation Board

IXZ-650EVB

GENERAL DESCRIPTION

The IXZ-650EVB provides a simple means of evaluating the IXZ-650 X- and Z-axis angular rate gyroscope. The gyro contains all required conditioning electronics in a single chip measuring 4 x 5 x 1.2mm. The IXZ-650 incorporates X- and Z-axis low-pass filters and an EEPROM for on-chip factory calibration of the sensor. Factory trimmed gyro scale factors eliminate the need for external active components and end-user calibration. A built-in Proportional-To-Absolute-Temperature (PTAT) sensor provides temperature compensation information. The product is lead-free and Green Compliant.

APPLICATIONS

- High-Performance Motion Sensing Game Controllers
- Pointing Devices
- Multimedia Remotes
- Computer Mice

PIN DEFINITIONS

Pin	Signal	Purpose
1	OUTX	Output of the X-Axis Gyro
2	HPS	Auto Zero Input
3	OUTZ	Output of the Z-Axis Gyro
4	TEMP	Temperature Sensor Output
5	VREF	Voltage Reference Output
6	GND	Ground
7	GND	Ground
8	+VOUT	VDD for Gyro
9	GND	Ground
10	+VIN	Input Supply Pin for LDO

FEATURES

- Fully-tested board for easy evaluation of dual-axis (X/Z) gyro
- Fully integrated X- and Z-axis gyros on a single chip
- 2000°/s full scale range
- 0.5mV/°/s sensitivity
- Integrated amplifiers and low-pass filters
- Auto Zero function for bias calibration
- On-chip temperature sensor
- High vibration rejection over a wide frequency range
- High cross-axis isolation by proprietary MEMS design
- 3V single supply operation
- Hermetically sealed for temp and humidity resistance
- 10,000 g shock tolerant
- RoHS and Green Compliant

ELECTRICAL SPECIFICATIONS

Parameter	Specifications	Unit
Full-Scale Range	±2000	°/sec
Sensitivity	0.5	mV/°/sec
Cross Axis Sensitivity	± 1	%
Non-linearity	< 1	% of FSR
Gyro Supply Voltage	3.0 ±0.3	V
Gyro Supply Current	7	mA
Operating Temperature	-20 to +85	°C
On time	50	ms
Shock Tolerance	10,000	g

COMPONENT PLACEMENT AND BOARD ORIENTATION

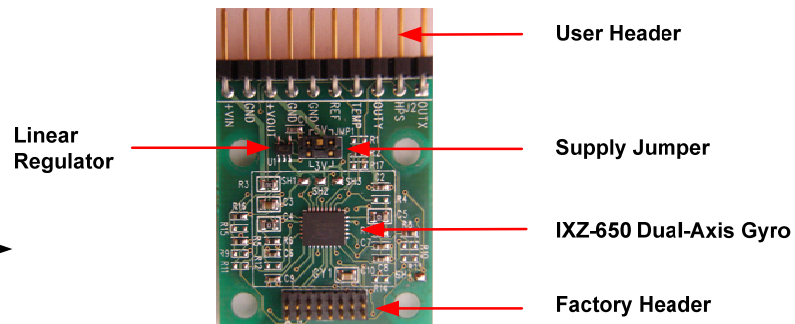
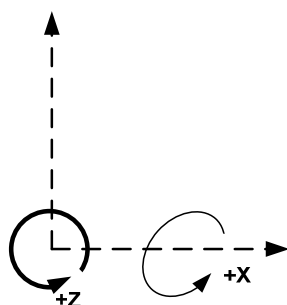

Purpose

This document provides the specification for the IXZ-650 Dual-Axis Gyroscope Evaluation Board configured per the table below.

Evaluation Board Configuration

Sensitivity	Internal LPF	External LPF
0.5 mV/deg/sec	140Hz	2kHz

IC Functional Block Diagram

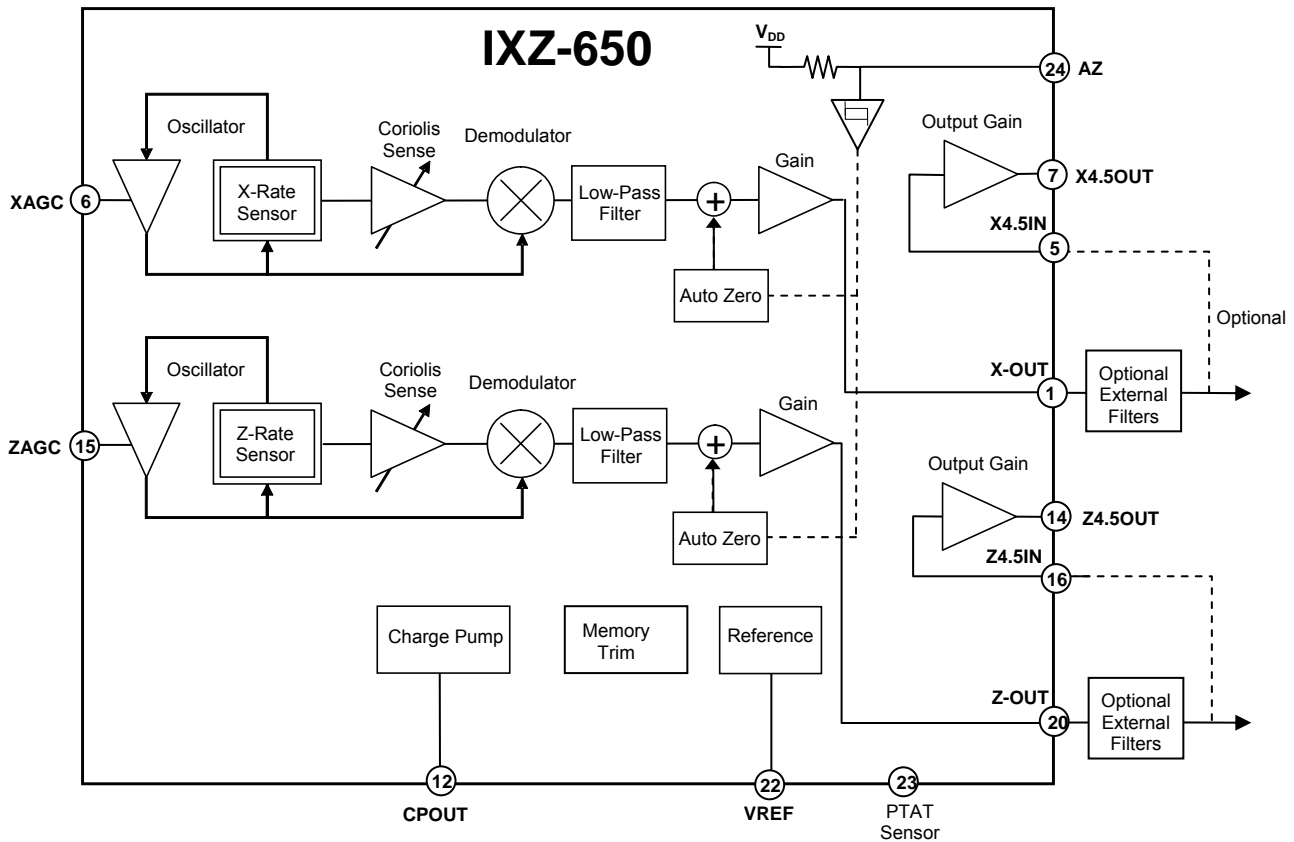

IXZ-650 Evaluation Board Configuration

Schematic

The schematic below specifies the components on the IXZ-650 Evaluation Board.

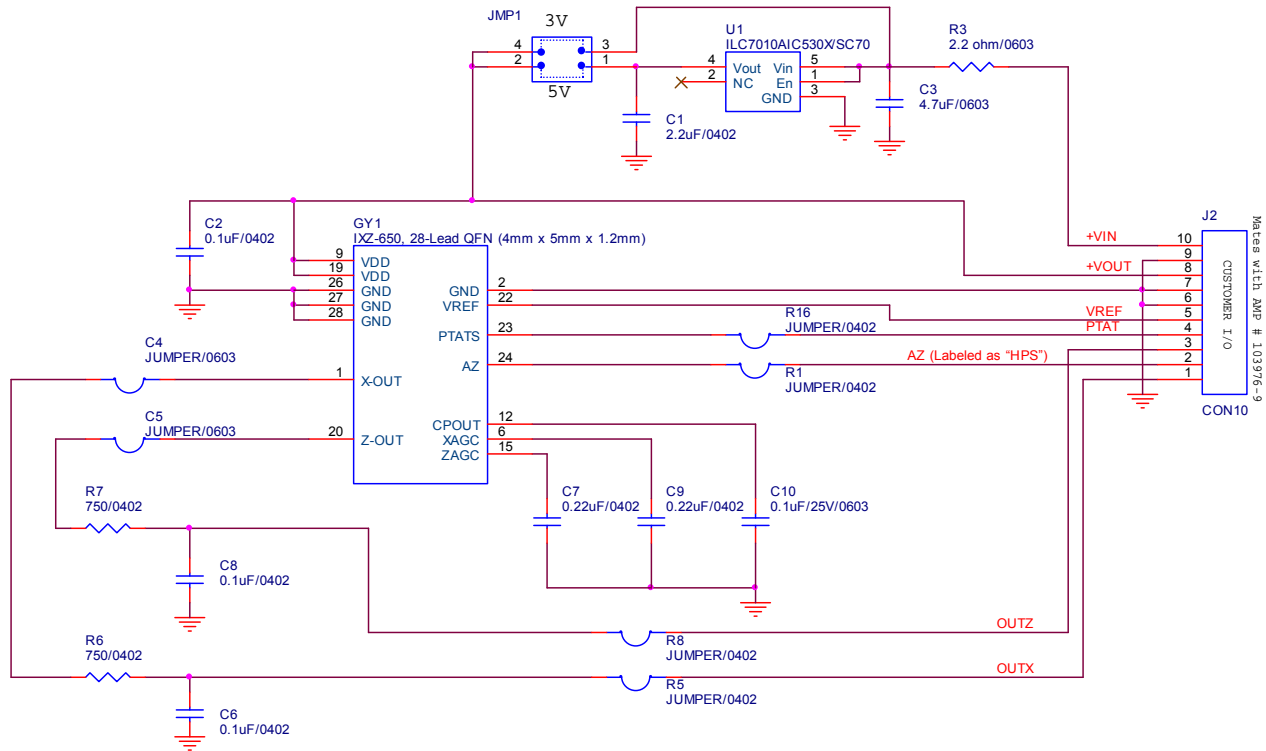

Bill of Materials

Reference	Part
C1	2.2 μ F/6.3V/Z5R/0402
C2,C6,C8	0.1 μ F/10V/X5R/0402
C3	4.7 μ F/6.3V/X5R/0603
C4,C5	JUMPER/0603
C7,C9	0.22 μ F/6.3V/X5R/0402
C10	0.1 μ F/25V/X5R/0603
GY1	IXZ-650, 28-Lead QFN (4mm x 5mm x 1.2mm)
JMP1	CON4A/0.050" X 0.1"
J2	Header 1x10, 0.1", 90D (Mates with AMP # 103976-9)
R1,R5,R8,R16	JUMPER/0402
R3	2.2 Ω /5%/0603
R6,R7	750 Ω /1%/0402
U1	Voltage Regulator 3.0V ILC7010AIC530X/SC70

Special Instructions

Electrostatic Discharge Sensitivity

The IXZ-650 gyro can be permanently damaged by an electrostatic discharge. ESD precautions for handling and storage are recommended.

Jumper Connector

The IXZ-650 evaluation board is equipped with a jumper connector to control the voltage supplied to the gyro. When the jumper is located in the “up” or standard position as shown in the picture above, the 5 Volts being supplied to the gyro is regulated to 3 Volts using an on-board regulator. When the jumper is located in the “down” position, the on-board regulator is bypassed and the gyro is being directly supplied with the voltage on Pins 9 and 19 of the IC.

Dimensional Drawing

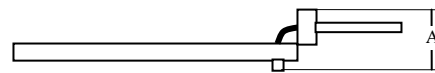
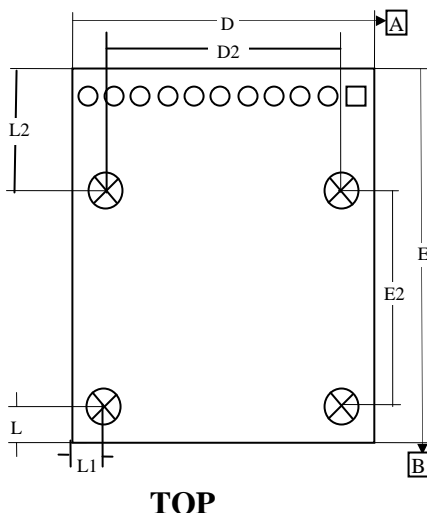

SIDE

Dimensions (mm)		
A	5.0	±1.0
D	25.7	±0.1
E	31.8	±0.1
L	3.1	±0.1
L1	3.1	±0.1
L2	10.2	±0.1
D2	19.5	±0.1
E2	18.5	±0.1

This information furnished by InvenSense is believed to be accurate and reliable. However, no responsibility is assumed by InvenSense for its use, or for any infringements of patents or other rights of third parties that may result from its use. Specifications are subject to change without notice. InvenSense reserves the right to make changes to this product, including its circuits and software, in order to improve its design and/or performance, without prior notice. InvenSense makes no warranties, neither expressed nor implied, regarding the information and specifications contained in this document. InvenSense assumes no responsibility for any claims or damages arising from information contained in this document, or from the use of products and services detailed therein. This includes, but is not limited to, claims or damages based on the infringement of patents, copyrights, mask work and/or other intellectual property rights.

Certain intellectual property owned by InvenSense and described in this document is patent protected. No license is granted by implication or otherwise under any patent or patent rights of InvenSense. This publication supersedes and replaces all information previously supplied. Trademarks that are registered trademarks are the property of their respective companies. InvenSense sensors should not be used or sold in the development, storage, production or utilization of any conventional or mass-destructive weapons or any other weapons or life threatening applications, as well as in any other life critical applications such as medical equipment, transportation, aerospace and nuclear instruments, undersea equipment, power plant equipment, disaster prevention and crime prevention equipment.

©2009 InvenSense, Inc. All rights reserved.